

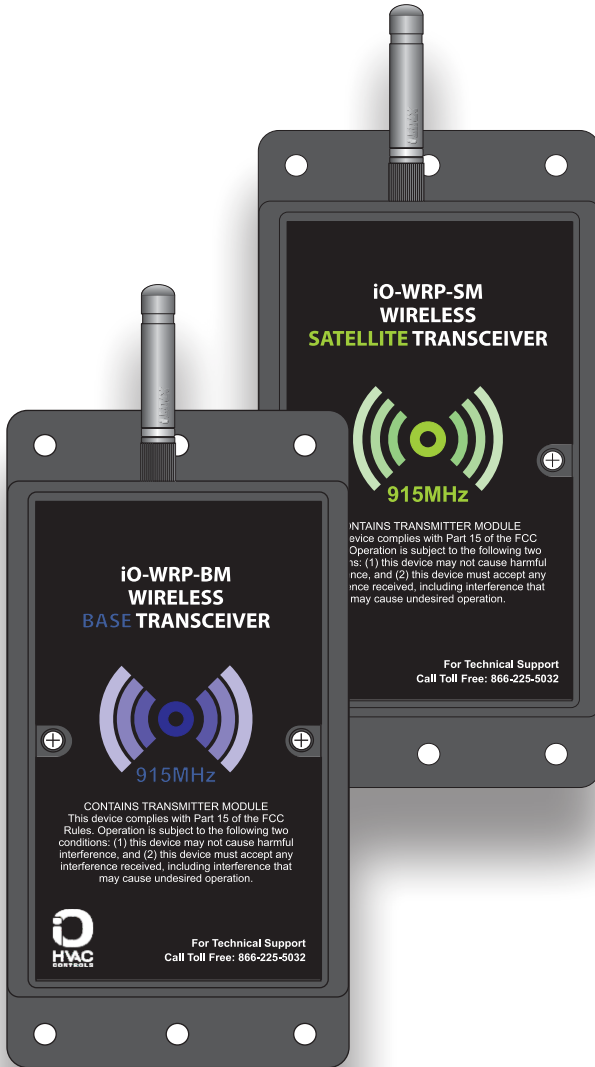

iO-WRP WIRELESS RELAY



INSTALLATION, OPERATION MANUAL

BLANK PAGE

iO-WRP WIRELESS RELAY Installation, Operation Manual



INTRODUCTION

The iO-WRP wireless relay system consists of 2 units; an iO-WRP-B Base Transceiver and an iO-WRP-S Satellite Transceiver. The base transceiver is equipped with 3 digital input channels and 1 relay output channel. The satellite transceiver has 1 digital input and 3 relay output channels. The digital inputs are compatible with 24VAC HVAC systems. The outputs are switched through onboard relays. When properly installed and configured, the iO-WRP system provides reliable wireless communication between two devices. Although the iO-WRP has a line-of-site transmission distance of up to 1,320 feet, unimpeded communication between the two devices can vary depending on size and composition of obstacles in the transmission path.

The iO-WRP communicates on the 915MHz frequency band and is FCC certified and approved for use in the United States, Canada, Australia and New Zealand.

Each transceiver is equipped with a bi-color LED that is used to indicate its operational state. The transceivers also have a momentary pushbutton which is used to "pair" two units together or "unpair" previously paired units.

NOTE: The wireless relay transceivers are already factory paired and will begin to communicate once 24 volts is applied to each unit.

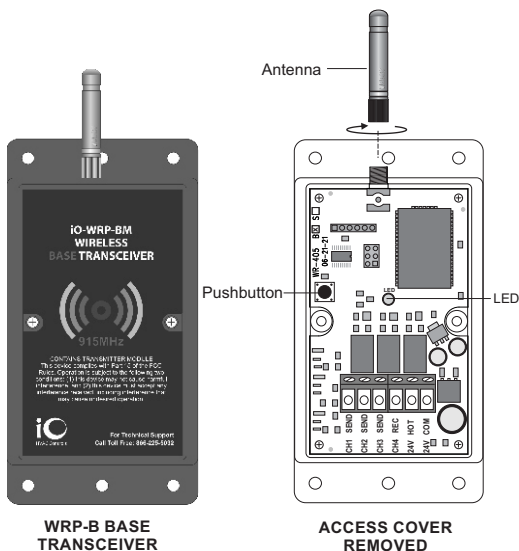

INSTALLATION

Both the base and satellite transceiver require continuous 24VAC.

iO-WRP-B Base Transceiver Module

1. Mount the iO-WRP-B Base Transceiver on a non-metallic surface in a location that allows access to the thermostat wiring at the indoor unit.

Do not mount inside the unit cabinet or inside any metal enclosure as this will greatly impede transmission distance.

2. Once the base transceiver is mounted, take the access cover off by removing the two screws. Refer to the iO-WRP wiring diagram that best suits the application. Depending on the application, not all channels may be required.

3. Use only 18-gauge solid (not stranded) thermostat wire. When connecting wires to the transceiver terminals, strip approximately 1/4" of insulation and push wire into designated terminal. Snug but do not over-tighten the terminal screws.

4. Make sure 24VAC power is off before connecting wires to the base transceiver.
5. After all wiring is completed, temporarily leave the access cover off and carefully attach one of the antennas provided with the iO-WRP transceivers.

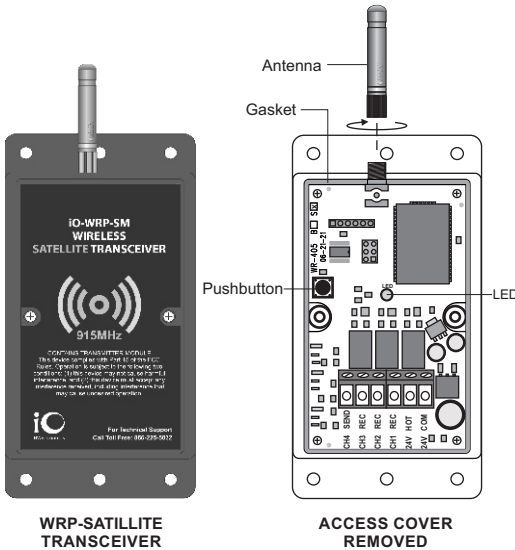

iO-WRP-S Satellite Transceiver Module

1. The iO-WRP-S Satellite Transceiver is mounted near or on the outside of the outdoor unit. The enclosure has a weather seal.

2. If 24VAC is not available from the indoor unit, a transformer must be installed in the outdoor unit to provide 24 VAC. Refer to the iO-WRP wiring diagram that best suits the application.

Do not mount inside the outdoor unit or inside any metal enclosure as this will greatly impede transmission distance.

3. Make sure that all power is off before connecting wires to the Satellite transceiver.
4. After all wiring is completed, temporarily leave the access cover off and carefully attach one of the antennas provided with the iO-WRP as illustrated.

Note: The iO-WRP-S Satellite Transceiver Module has a weather resistant gasket seated in the enclosure. Make sure the gasket stays in place during installation. There are two antenna gaskets included with the iO-WRP kit. One will be used on the iO-WRP-S Satellite Transceiver Module during final assembly.

TYPICAL WIRING DIAGRAMS

The following wiring diagrams illustrate the most common HVAC applications for the iO-WRP but do not limit it from being used in other wireless applications.

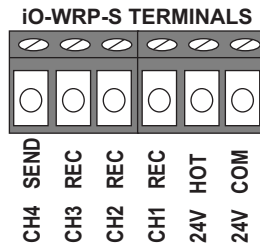
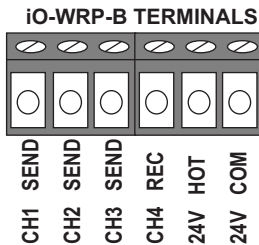

Please note the difference in terminal designations between the iO-WRP-B Base Module and the iO-WRP-S Satellite Module. The iO-WRP-B Base Module has three send and one receive channel. The iO-WRP-S Satellite Module has three receive and one send channel.

SINGLE OR MULTI-STAGE COOLING WITH BROKEN WIRE TO OUTDOOR UNIT

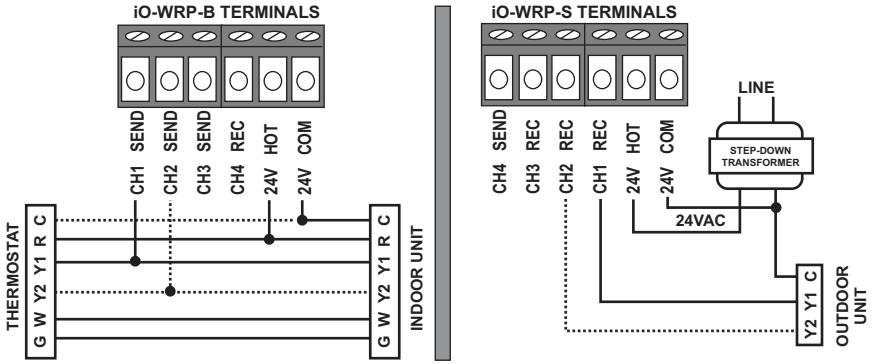

HEAT PUMP UPGRADE WITH ONLY TWO WIRES TO OUTDOOR UNIT

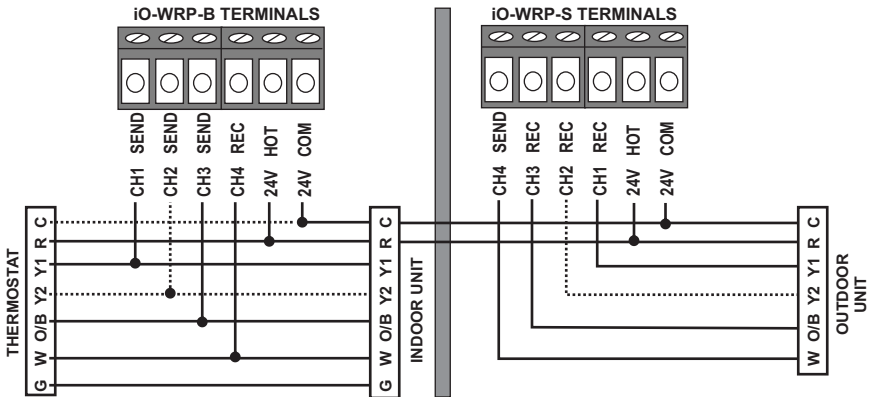

HEAT PUMP UPGRADE WITH NO WIRES TO OUTDOOR UNIT

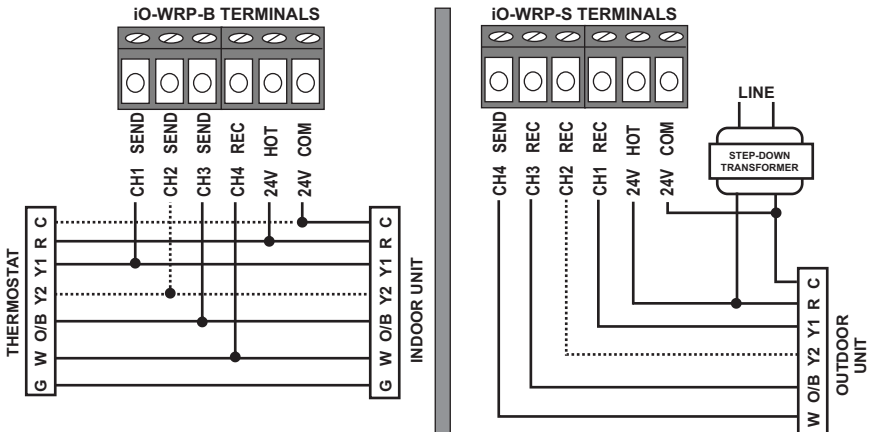

TEST, CHECK AND START-UP

1. Once all wiring is completed, apply 24 VAC to both transceivers.
2. Turn the thermostat or control device off so that no signal is sent.

LED BEHAVIOR IN PAIRED MODE

- GREEN** - When 24 VAC is applied, each transceiver LED will be solid green.
- RED** - Each module LED will flash red briefly when a data message is sent and go solid red up to 10 seconds until transmission is confirmed.
3. If LED status indicates communications between the transceivers, send signals can now be applied from the thermostat or control device and operation of the outputs confirmed.
 4. Once operation is confirmed, carefully slide the iO-WRP-B access cover over the antenna and the iO-WRP-B enclosure and re-attach using the screws provided. Carefully slide the iO-WRP-S satellite access cover over the antenna and the iO-WRP-S enclosure making sure that the gasket is properly fitted and re-attach using the screws provided.
 5. Take one of the antenna gaskets provided in the kit and slide it down over the iO-WRP-S satellite antenna until it creates a tight seal.
 6. It is recommended that silicon caulk be used to seal the wire access hole on the iO-WRP-S satellite transceiver as an added protection against moisture and insects.
-

LOSS OF COMMUNICATIONS AND PROBABLE CAUSES

Each transceiver has a built in inactivity timer to detect a loss of communications. If no data is received from a paired set for one minute, all outputs are turned off and the LEDs will display solid red.

If a factory paired set of transceivers indicate a loss of communications, it is typically due to one of the following reasons:

1. Communications being blocked by metal enclosures or other construction materials such as plaster or stucco surfaces containing wire lath, concrete with Rebar, stone or metal fencing.
 2. Electromagnetic Interference (EMI) from power lines, radio, TV and cellular towers or conducted noise from electric motors can also effect communications.
 3. Greater distance between the transceivers can also contribute to communications being intermittently or permanently lost.
-

PAIRING TRANSCIVERS

Since the transceivers have been paired at the factory, it is highly unlikely that they will require re-pairing. However, it may be necessary in the event one of the transceivers requires replacement.

1. After all wiring is performed, apply 24VAC to both the base and satellite transceivers.
2. The base transceiver LED will flash between red and green at a rate of 3 times per second. When in this mode, the base will broadcast a pair request message once every 5 seconds until it receives a pair response from the satellite transceiver.
3. The satellite LED will flash red every 3 seconds. Press and hold down the pushbutton on the satellite transceiver until it starts flashing red and green every 3 seconds. Once this pattern appears on the LED, release the pushbutton.
4. Pairing is confirmed when both transceiver LEDs go solid green. Once paired, the transceivers will poll each other every 15 seconds regardless whether any digital input signals are activated. The LEDs will flash red briefly when a data message is sent and go solid red up to 10 seconds until transmission is confirmed.

Note: When using multiple iO-WRP wireless relays in the same location, only power up one base and one satellite to be paired at a time.

UNPAIRING TRANSCEIVERS

Unpairing a base and satellite transceiver is accomplished by holding down the button while applying 24VAC and continuing to hold the button down for about 5 seconds. While the button is held down, the LED will flash between red and green 5 times per second. Once the unpairing process is complete, the LED will flash as described in the pairing section. If the button is released prior to the completion of the unpairing process, the transceivers will transition to the paired mode, retaining their previous paired status.

SPECIFICATIONS

Power:	24VAC, 2.8VA
Channels:	Base: 3 Send - 1 Receive Satellite: 3 Receive - 1 Send
Contact Rating:	1 Amp per channel
Frequency:	915MHz Operation
Range:	Up to 1,320 ft.
Dimensions:	2-5/8" W x 5-1/8" H x 1-1/8" D

COMPLIANCE

The iO-WRP Wireless Relay System has been tested and found to comply with the limits for a Class B digital device, pursuant to part 15 of the FCC Rules. These limits are designed to provide reasonable protection against harmful interference in a residential installation. This equipment generates, uses and can radiate radio frequency energy, and if not installed and used in accordance with the instructions, may cause harmful interference to radio communications. However, there is no guarantee that interference will not occur in a particular installation. If this equipment does cause harmful interference to radio or television reception, which can be determined by turning the equipment off and on, the user is encouraged to try to correct the interference by one or more of the following measures.

- Reorient or relocate the receiving antenna.
 - Increase the separation between the equipment and receiver.
 - Connect the equipment into an outlet or circuit different from that to which the receiver is connected.
 - Consult the dealer or an experienced radio/TV technician for help.
-

TECHNICAL SUPPORT

iO HVAC Controls is committed in providing the highest level of technical support. If you are experiencing difficulty with your iO-WRP installation and require trouble shooting assistance, call 866-225-5032. You can also learn more about our products by going to iohvaccontrols.com.



www.iohvaccontrols.com

For Technical Support Call Toll Free: 866-225-5032

iO-06-1345-112222